

## Type RPC-QR2 Carriage Mounted Roll Prong (Class II)

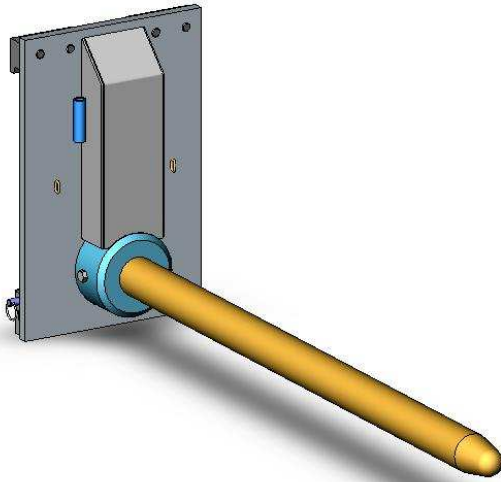

The type RPC-QR2 Carriage Mounted Roll Prong is suitable for carpet, vinyl, fabric or similar products. This unit has been designed with a Class II mounting and features Quick Release lower Carriage Hooks and a spring loaded locating pin for easy installation.

Prongs are manufactured from high tensile steel and can be made to any length. The Safe Working Load (SWL) of this unit varies depending on Prong chosen. For Class III mountings refer RPC-QR3.

### SPECIFICATIONS:

- Safe Working Load (SWL) – refer chart below
- Lost Load 100mm
- Unit Weight – refer chart below
- Standard finish – painted enamel
- Refer diagram below for all other specifications

(RPC-QR2 with Ø70mm Prong shown)

