

CROWN

Specifications

WP 2300 Series

Walkie Pallet
Truck

WP 2300

Series



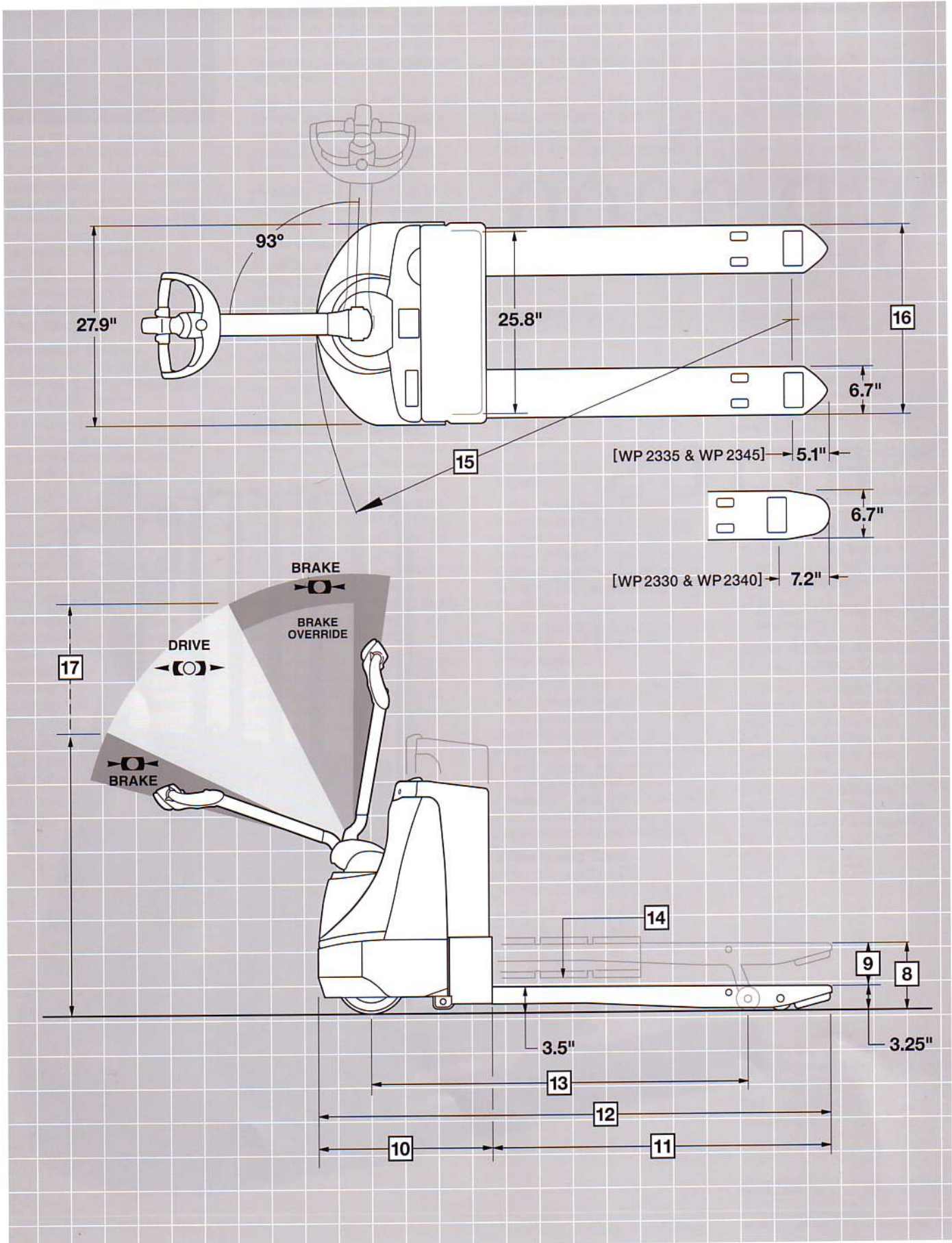

General Info	1	Manufacturer		Crown Equipment Corporation				
	2	Model		WP 2330	WP 2335	WP 2340	WP 2345	
	3	Load Capacity	lb	4500	4500	4500	4500	
	4	Power	Electric	24 Volts	24 Volts	24 Volts	24 Volts	
	5	Operator Type	Stand-up	Walkie	Walkie	Walkie	Walkie	
Dimensions	8	Lift Height	in	9.25	8.5	9.25	8.5	
	9	Lift	in	6	5.2	6	5.2	
		Battery Compartment	Length	in	7.9	7.9	9.1	9.1
	10	Head Length	in	23.2	23.2	24.4	24.4	
	16	Outside Fork Spread	in	21.3/26.4	21.3/26.4	21.3/26.4	21.3/26.4	
	17	Tiller Arm Height in Drive Position	Min/Max	in	31.1 / 47.5			
	18	Travel Speed	Empty/Loaded	mph	3.7 / 3.4			

Forks	WP 2300 Series			WP 2330	WP 2335	WP 2340	WP 2345	
		Nominal Fork Length	in	36/42/48	48	36/42/48	48	
	11	Actual Fork Length	in	35.6/41.7/47.6	45.5	35.6/41.7/47.6	45.5	
	12	Overall Length	in	58.8/65.0/70.9	67.7	60.0/66.1/72.0	69.9	
	13	Wheelbase	Lowered	in	44.2/50.3/56.2	55.2	45.4/51.5/57.4	56.4
			Raised	in	39.7/45.8/51.7	52.1	40.8/46.9/52.8	53.3
	14	Grade Clearance*		%	52.7/44.5/38.7	31.6	50.9/43.2/37.8	30.6
			Gradeability	Loaded	%	10	10	10
	15	Turning Radius	in	51.6/57.7/63.6	62.6	52.8/58.9/64.8	63.8	
	7	Truck Weight**	Less Battery	lb	712	712	712	712

* Determined with forks raised

**With 48" forks

WP 2300 Series

Technical Information

Standard Equipment

- 24-volt fused electrical system
- MOSFET transistorized traction control system
- Separately excited drive motor (SEM)
- Electric brake
- Brake override
- Anti-roll down
- Regenerative motor braking
- Heavy-duty drive unit
- Drive unit enclosed in high ductile strength steel frame
- Stamped steel power unit cover
- Safety reversing button
- Roll formed forks with pull rod height adjustment
- 175 amp connector with quick disconnect
- Color-coded wiring
- Two pre-programmed performance levels
- 10" x 4" wide rubber drive tire
- 3.25" x 4.5" wide Vulkollan load wheels with debris guard
- Low overall height for fork and load visibility
- Paper retainer on battery cover (WP 2330 and WP 2335)
- Horn
- Key switch

Optional Equipment

- Casters
- Hour meter
- Discharge indicator
- Curtis Unigage includes hour meter, discharge indicator with interrupt
- Handset analyzer for calibration or fault analyzing
- 30 amp fully automatic charger
- 48", 60" or 72" high load backrest
- Maintenance free or swing-out battery package
- Freezer/corrosion conditioning
- Polyurethane drive tire
- Non-marking rubber tire
- Siped rubber drive tire
- Keyless on/off toggle switch in lieu of key switch
- Drive/tow switch
- Battery straps

Battery and Charger

Two battery compartments are available to suit your duty cycle.

The 7.9" battery compartment (WP 2330/WP 2335) is designed for the battery package. Battery package options are as follows:

- Maintenance-free battery pack, four 6-volt batteries at 195 amp hour
- Wet-cell swing-out battery pack, four 6-volt batteries at 160 amp hour
- Dry-cell swing-out battery pack, four 6-volt batteries at 160 amp hour

The optional nylon battery straps secure the batteries to the stand to minimize vibration in rough floor or over dock applications, reducing potential damage to the batteries or the stand.

The 9.1" battery compartment (WP 2340/WP 2345) will accept an industrial storage battery up to 300 amp hour capacity.

A built-in 30 amp charger is available as an option on all models. This premium fan cooled solid-state charger is durable and efficient. It has an advanced memory feature to allow for opportunity charging. The charger can be set for either maintenance-free, wet-cell or industrial batteries. An extension cord is included with any truck equipped with the built-in battery charger.

Operator Controls

The WP's robust X10™ control handle is designed to allow for an optimum turning radius with low steer effort. All control buttons can be operated with either hand and can be accessed with minimum hand and wrist movement. The horn switches are integrated in the hand grips. An ergonomic forward/reverse thumb wheel allows for precise maneuvering. Depending on the conditions, maximum travel speed can be reduced via the rabbit/turtle switch. The parking brake is activated at the lower and upper end of the tiller position.

WP 2300 Brake Override Function

For easy operation in tight areas a brake override function is incorporated which allows the WP 2300 to be driven safely and precisely at creep speed with the handle in a near vertical position. The control handle remains within the profile of the power unit at all times, even when performing 90° turn.

When the forward/reverse thumb wheel is in neutral the parking brake is immediately activated thus preventing unexpected movement.

Performance

The WP 2300 benefits from Crown's design and engineering excellence.

The transistor control module works in conjunction with a new separately excited (SEM) drive motor to provide excellent acceleration and top travel speed loaded or empty. Good acceleration enhances efficient pallet entry and exit to increase productivity. Transistor control is programmable for specific tasks or operator skill levels.

Smooth travel and lift combine with excellent controls to reduce product damage and increase productivity.

Electrical System

A heavy-duty 24-volt fused electrical system provides good travel and lift speeds.

Separately excited motor control eliminates directional contactors reducing maintenance and downtime.

The transistor control is sealed from dirt, dust and moisture for trouble-free operation. Transistor control features include over-temperature protection, polarity protection, self-test and visible diagnostics.

Regenerative motor braking is activated under a downhill condition, during plugging or when the directional control is returned to neutral. "Regen" reduces heat build-up and extends motor brush life.

An anti-roll down feature will apply the brakes if the truck rolls without a travel command.

175-amp battery connector with standard disconnect handle.

Hydraulic System

Heavy-duty 4" diameter hydraulic motor with integral pump and reservoir for maximum efficiency and durability.

Twin, hard-chromed lift cylinders provide improved load stability. Additionally, smaller twin lift cylinders reduce truck length, improving maneuverability.

Hydraulic lines, fittings and elbow connections are minimized to reduce heat from hydraulic oil flow and improve efficiency.

At full lift, a top of stroke cutout switch shuts the lift motor off, which saves energy and prevents motor overheating.

The totally enclosed system is protected by pressure, suction and return line filtration. A convenient fill plug allows for easy fluid level checks.

Drive Unit and Brakes

Heavy-duty gear box with spur gears for low noise emission.

Drive unit is equipped with an electromagnetic disc brake that is spring applied and electrically released. Brake is activated by the control handle position. Brake rotor and disc are easily accessed for inspection and replacement. Regenerative motor braking assists brake effort and improves component life.

Drive unit mounts in truck frame with a permanently lubricated, twin conical roller bearing that disperses load forces evenly, reducing maintenance and downtime.

Forks

The WP 2300 has two fork styles to suit the application.

The Crown "profiled fork" offers tapered fork tips with shorter lengths and wheelbase to improve the turning radius and facilitate load handling in tighter areas.

The standard fork design has 6" of lift with a conventional fork tip and comes in 36", 42" and 48" lengths. Fork spreads are 22" or 27" wide.

The forks are roll-formed for maximum strength and the pull rods incorporate fork tip adjustment to aid in pallet entry/exit.

All pivot points have Teflon-impregnated, bronze, steel-backed bushings. In addition, each pivot point is provided with a grease fitting to flush out dirt and moisture, reducing downtime and providing increased service life.

Serviceability

One piece steel power unit cover is removed easily for access to all major components.

Fork adjustment is done easily using the threaded pull rod.

Brake rotor and disc inspection and replacement are easy.

Drive motor brush access is excellent.

Color-coded wiring speeds troubleshooting and the Crown transistor uses visible LED flashes for fault communication. Optional plug-in analyzer for servicing and programming capability.

Control handle switch cap is easily removed to expose components.

InfoPoint™ allows your technician to troubleshoot without complicated schematics, wiring diagrams or cumbersome service manuals for over 95 percent of your repairs. Simplicity is complete with InfoPoint Quick Reference Guide, color component maps and "Information nuggets" located on the truck.

Wheels and Tires

Drive tire - solid rubber
10" dia x 4" wide x 6.5" hub

Load wheels - Vulkollan
3.25" dia x 4.5" wide

Optional casters are
3.5" dia x 2" wide

Pallet Planning Guide

On WP 2300 models the load wheel will drop into the second opening of the pallet. When "A" dimension equals nominal fork length, "C" dimension is 6" maximum and "B" is 14" minimum.

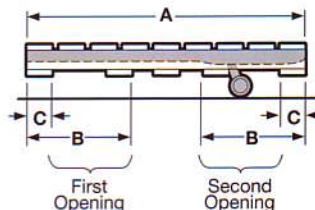

Other Options

- 1. Audible travel alarm
- 2. Flashing lights

Safety considerations and dangers associated with audible travel alarms and flashing lights include:

- Multiple alarms and/or lights can cause confusion.
- Workers ignore the alarms and/or lights after day-in and day-out exposure.
- Operator may transfer the responsibility for "looking out" to the pedestrians.
- Annoys operators and pedestrians.

Other Options Available

Contact your local Crown dealer.

Dimensions and performance data given may vary due to manufacturing tolerances. Performance is based on an average size vehicle and is affected by weight, condition of truck, how it is equipped and the conditions of the operating area. Crown products and specifications are subject to change without notice.



Crown Equipment Corporation
New Bremen, Ohio 45869 USA
Tel 419-629-2311
Fax 419-629-3796
crown.com

Because Crown is continually improving its products, specifications are subject to change without notice.

Crown, the Momentum symbol, InfoPoint and The X10 Handle are trademarks of Crown Equipment Corporation.

Copyright 2004 Crown Equipment Corporation
SF14424 6/04
Printed in U.S.A.